

SFD-SFDE Floodlights for halogen and discharge lamps

Explosion Proof Electrical Equipment



Ex Lighting

Installation: hazardous areas - Zone 1 / 2 (Gases) - Zone 21 / 22 (Dusts)
Classification: Group II - Category 2G 2D



SFD-SFDE

www.feam-ex.com

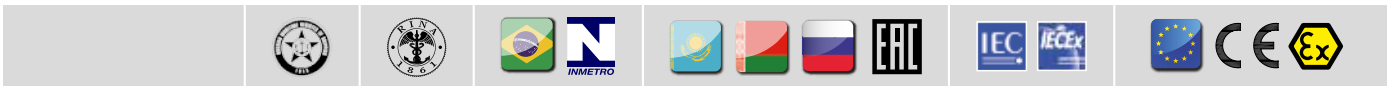

REFERENCE STANDARDS

Directive 94/9/EC (until April 19th, 2016) - Directive 2014/34/EU (from April 20th, 2016)	
EXECUTION	<ul style="list-style-type: none"> ⊗ II 2 G Ex d IIB + H2 T3/T2 or ⊗ II 2 G Ex de IIB + H2 T3/T2 ⊗ II 2 D Ex tb IIIC T200°C...T240°C
RULES OF COMPLIANCE	EN/IEC 60079-0; EN/IEC 60079-1; EN/IEC 60079-7; EN/IEC 60079-31
EC Type-Examination Certificate	INERIS 01 ATEX 0018
PROTECTION DEGREE	IP66
AMBIENT TEMPERATURE	-20°C ÷ +60°C
OTHER AVAILABLE CERTIFICATES	<ul style="list-style-type: none"> IECEX: IECEX INE 15.0003X INMETRO: CEPEL 15.2363X EAC: TC RU C-IT.ГБ08.В.01342 (-60°C÷+60°C) RINA: ELE18111CS_014 RUSSIAN MARINE CERTIFICATE (RMRS): 13.03516.315

Mechanical characteristics

Body	marine grade copper free aluminium
Diffuser	tempered front glass
Support	adjustable type hot dip galvanized steel
Reflector	internal polished aluminium
Painting	external epoxy powders grey RAL-9006 COLOUR
Screws	external stainless steel
Gaskets	silicon rubber
Cable entry	ISO-M20 / 3/4" NPT

Electrical characteristics

Power supply	conventional ballast 230v - 50hz (p.f.corrected - cos ρ ≥ 0,95)
Lampholders	porcelain e40 size
Internal wiring	high-temperature resistant silicon rubber insulation cables
Terminals	suitable up to 4sq/mm cables

On request accessories:

- External painting colour on request
- Control gear with voltage supply different than standard
- Threaded cable entry different than standard



SFD-SFDE Technical data

CODE	LAMP	TEMPERATURE CLASS (GAS)	TEMPERATURE CLASS (DUSTS)	LAMPHOLDER SIZE	CABLE ENTRY SIZE	DETAIL
------	------	-------------------------	---------------------------	-----------------	------------------	--------

LIGHTING FIXTURE FOR HALOGEN LAMP - POWER SUPPLY 230V-50Hz

SFD500IA	500 W	T2	T 217°C T 230°C T 240°C	R7s	2 x 3/4" NPT	A
SFDE500IA					2 x ISO-M20	B

LIGHTING FIXTURE FOR HIGH PRESSURE SODIUM LAMP - POWER SUPPLY 230V 50Hz

SFD150HPNA	150 W	T3	T 200°C	E-40	2 x 3/4" NPT	A
SFDE150HPNA					2 x ISO-M20	B
SFD250HPNA	250 W	T3 / T2	T 200°C / T 210°C	E-40	2 x 3/4" NPT	A
SFDE250HPNA					2 x ISO-M20	B
SFD400HPNA	400 W	T3 / T2	T 200°C / T 210°C / T 220°C	E-40	2 x 3/4" NPT	A
SFDE400HPNA					2 x ISO-M20	B
SFDE600HPNA	600 W	T3	T 200°C	E-40	2 x 3/4" NPT	C

LIGHTING FIXTURE FOR METAL HALIDE LAMP - POWER SUPPLY 230V 50Hz

SFD250MH	250 W	T3	T 200°C	E-40	2 x 3/4" NPT	A
SFDE250MH					2 x ISO-M20	B
SFD400MH	400 W	T3 / T2	T 200°C / T 210°C / T 220°C	E-40	2 x 3/4" NPT	A
SFDE400MH					2 x ISO-M20	B

SFD-SFDE Technical features

CODE	A [mm]	B [mm]	C [mm]	D [mm]	E [mm]	F [mm]	WIGHT [Kg]	CABLE ENTRY	DETAIL
SFD...	485	435	290	270	500	75	25,00	2 x 3/4" NPT	A
SFDE...	485	435	290	270	500	88	25,00	2 x ISO-M20	B
SFDE600HPNA	485	590	290	270	420	240	30,00	2 x 3/4"NPT	C

Reference details

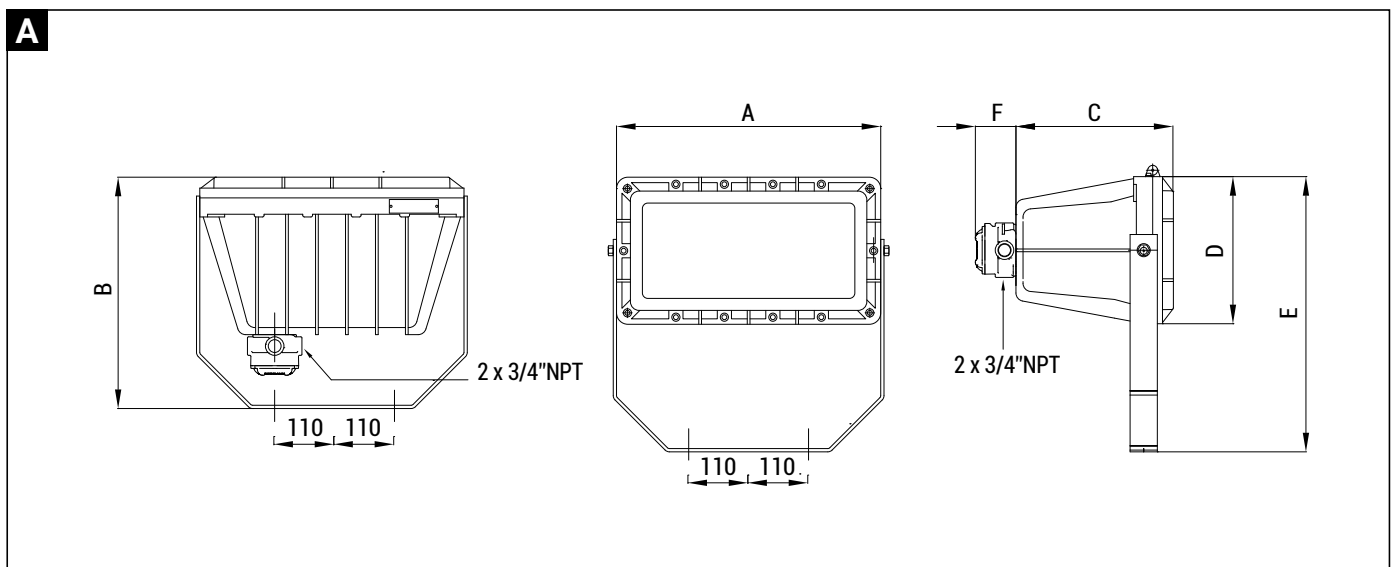



SFD-SFDE Technical features

Reference details

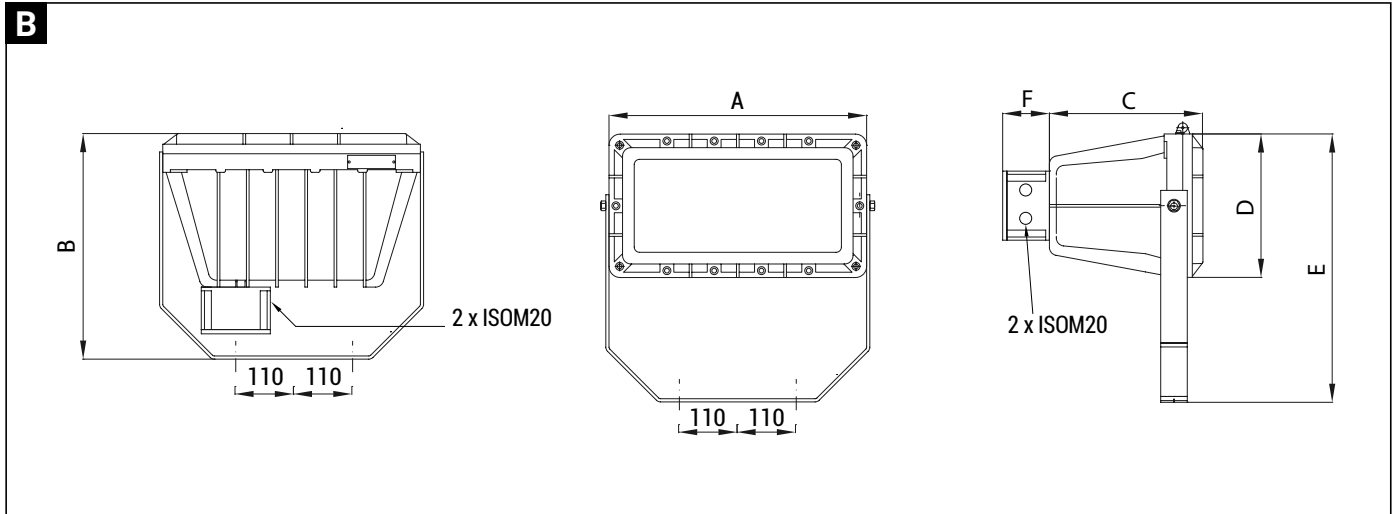

Reference details

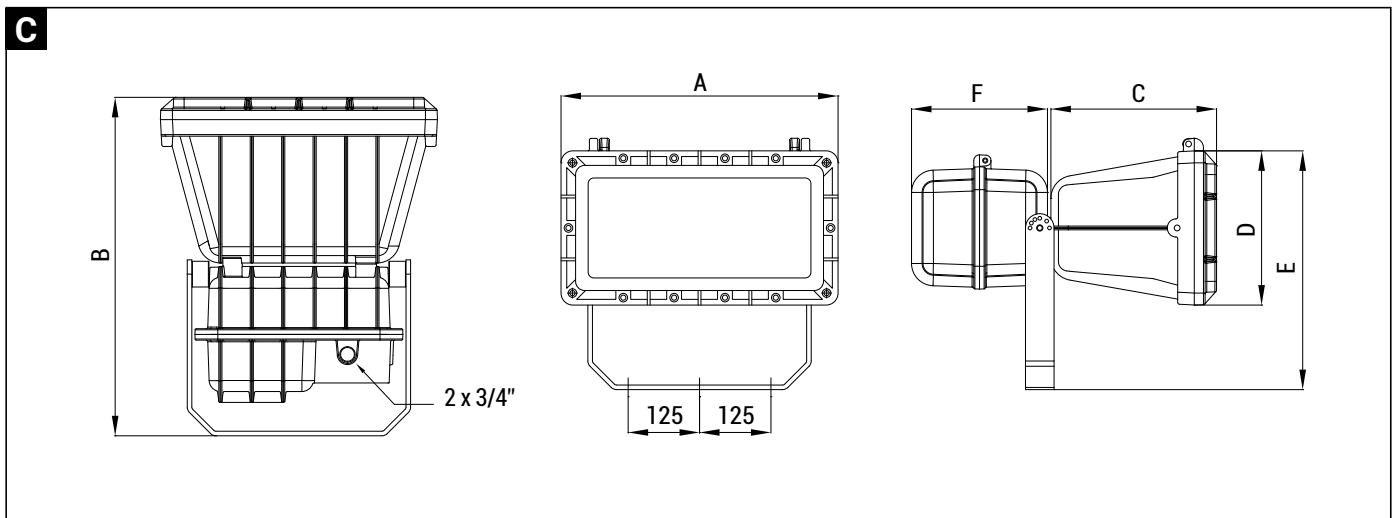

SFD-SFDE Polar diagrams – photometric data

SFD150HPNA

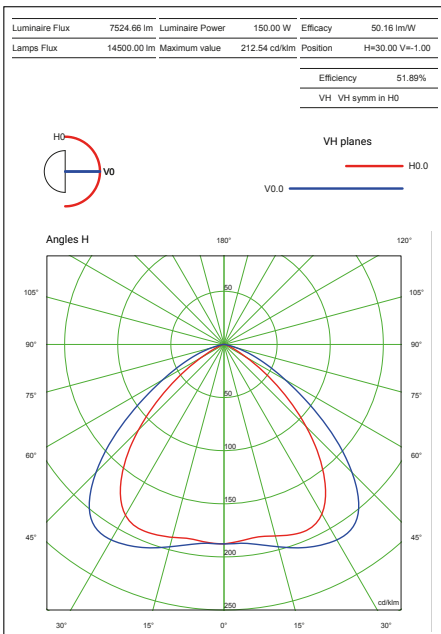

SFDE250HPNA

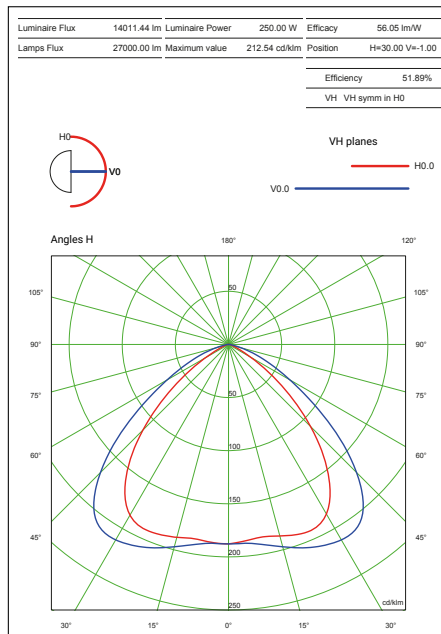

SFD250MH

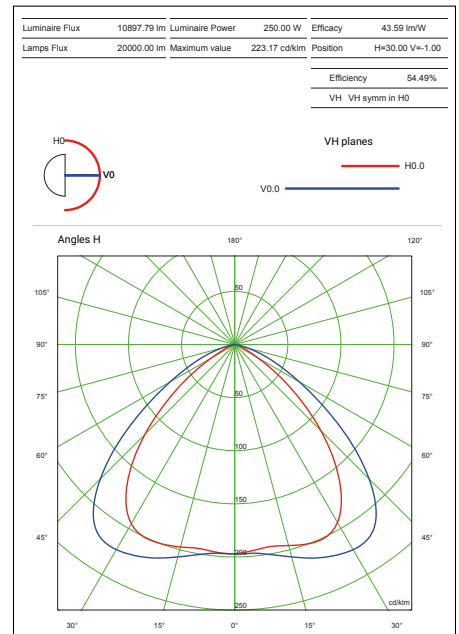



SFD400HPNA

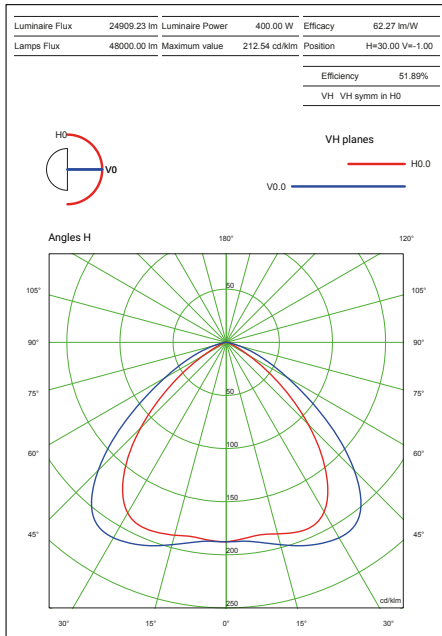

SFD400MH

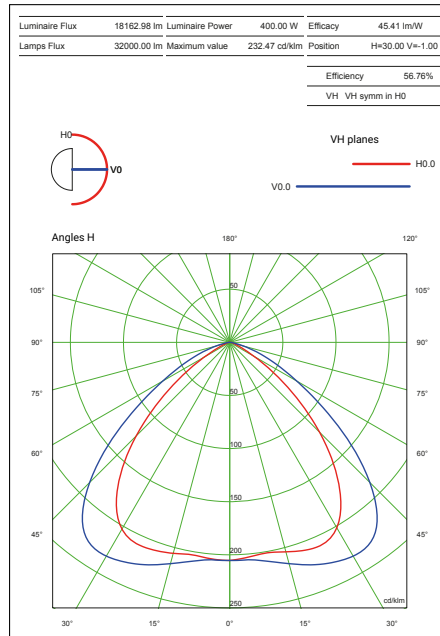

SFD500IA

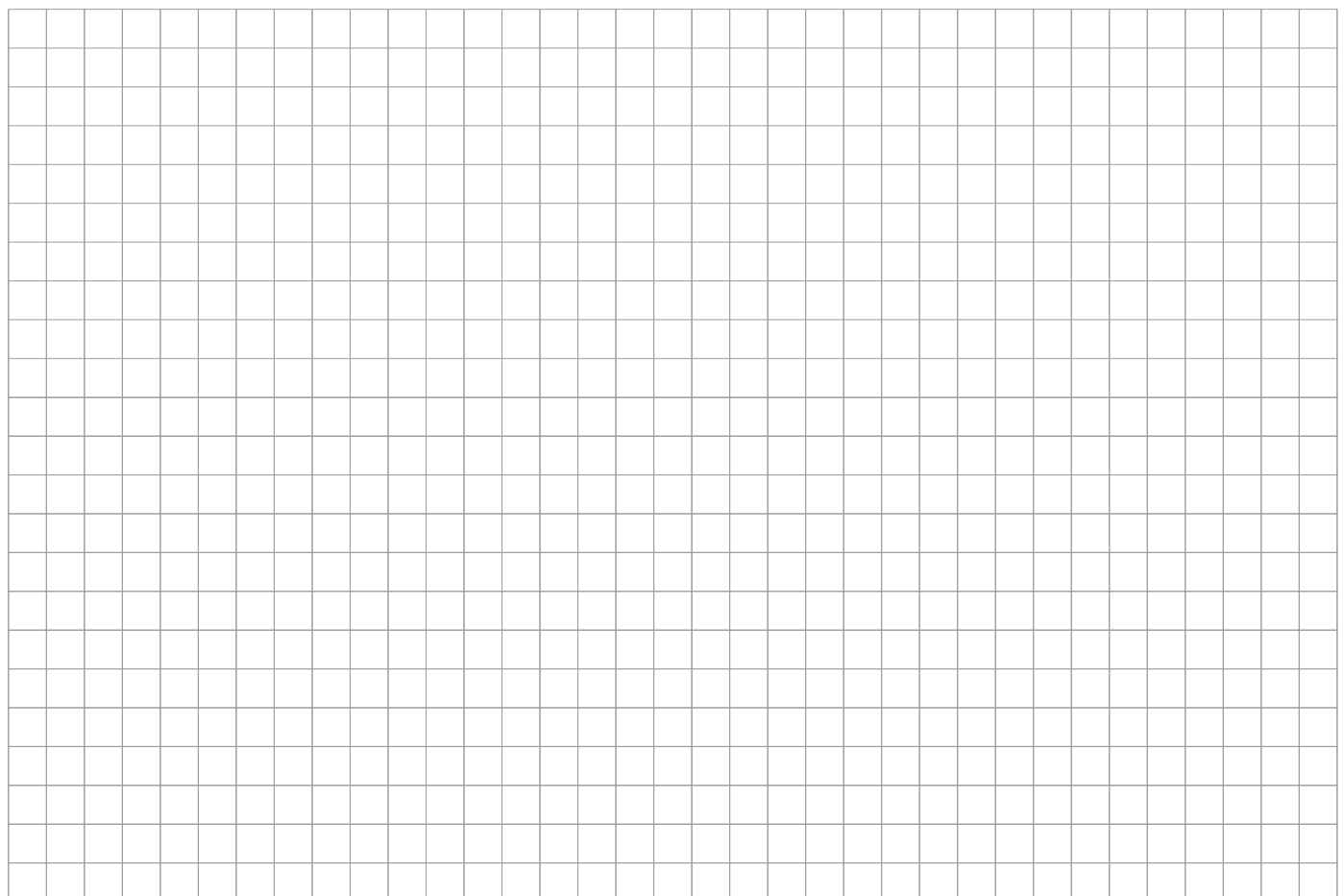
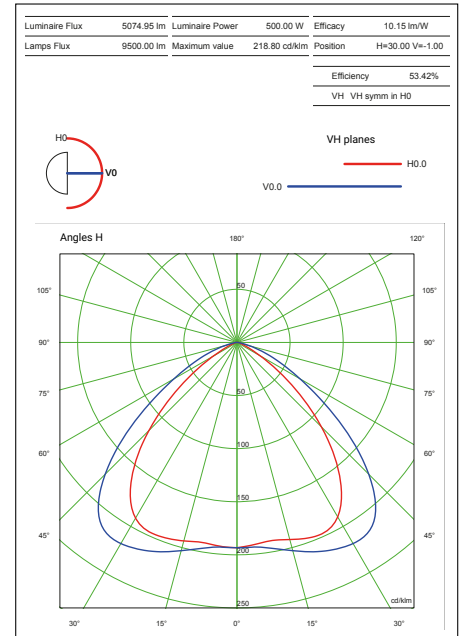

REMARK:

Due to the development of the national and international specifications and of the technology, the above technical characteristics showed on this bulletin can be considered as binding on our confirmation only.