

## PE Series P-XY12PE Data sheet



### Description

- PE Series detectors can reliably detect flammable/explosive gases and offer cost-effective solutions for many applications in classified areas.
- Standard 4-20mA Analog Output
- Optional 2 Relay (Alarm 1 - Alarm 2) outputs.
- 1/2" NPT Cable Gland
- Zone 1 and Zone 2

Table 1: PE Flammable Gas detectors

XY	Gases	Product Code	Measuring Range	LEL(Vol)
30	LPG	P-3012PE	0-100% LEL	1,8
31	Methane	P-3112 PE	0-100% LEL	4,4
32	Petrol Vapors	P-3212 PE	0-100% LEL	1,2
33	n-Butane	P-3312 PE	0-100% LEL	1,6
34	Propane	P-3412 PE	0-100% LEL	2,1

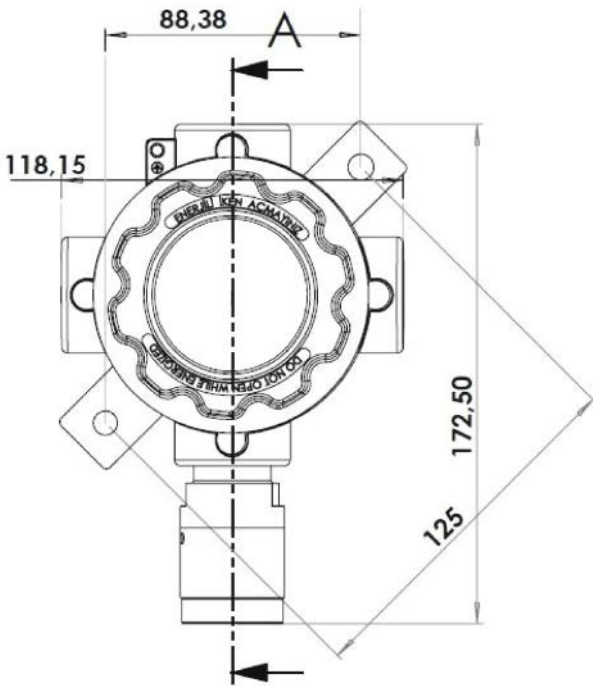

### Optional Modules

- P-2R: 2 Alarm output, NO/NC relay card.

### Applications

- Boiler rooms
- Laboratories
- Light industrial applications
- LPG Stations

Specification	Flammable Gases
Sensing Element	Catalytic
Measurement Unit	LEL
Output Signal	4-20mA
Sensor Warm-up Time	60 sec
Response Time(T90)	<15 sec
Measuring Range	0-100% LEL
Accuracy	%±2
Operating Temperature	-20°C ~ +50°C
Humidity	5 ~ 95 %RH
Input	12- 28 VDC
Power Consumption	Max. 2W
Output Options	Optional 2 NO/NC Relay
Relay	Alarm 1, Alarm 2 NO/NC De-energized
Cable Entry	1/2" NPT Cable Gland
IP Rating	IP65
Junction Box	Die-cast aluminium
Sensor Head	Nickel-plated Brass SH10
Dimensions/Weight	172,5 x 118,15 x 88 mm (1150gr)
Hazardous Class	Zone 1 and Zone 2
Standards	EN 60079-0 EN 60079-1 EN 60079-18
Certificates	IECEx IMQ 18.0009X IEP 12 ATEX 082

- Prosense gas detectors are fully tested and calibrated before delivery. Gas Detectors must be routinely checked and calibrated to ensure fully operational at all times regarding EN 60079:29-2.