



Explosion proof Emergency Light



Technical Parameters

Type	BCJ	
European (ATEX)	ECM 21 ATEX-B D077	CE 1282  II 2G Ex d e IIC Gb
Gas and Dust	ECM 21 ATEX-E D078	CE 1282  II 2D Ex tb Db
Input voltage	220VAC, 50-60 Hz	Degree of protection IP66
Power consumption [W]	2x3	Conduit Entries G 3/4" (10-14mm)
Back-up Battery	>120min	Weight 2.60 kg
Mounting Styles	Ceiling; Wall; Base Mount	

Explosion proof Emergency Light

Features:

- * Zone 1&2, Zone 21&22
- * Built-in maintenance-free battery pack, the battery will be charged automatically when power is supply. And it will will be in emergency light when the power fails.
- * The lamp head can be rotated around 270° from top to bottom, with wide lighting range.
- * Easy to install.
- * LED indicator of main, charge, fault to easy to know the status of the light.
- * Self inspections annual month. And test button for testing any time for user.
- * Equipped with an explosion-proof buzzer with a 65dB-85dB voice. When the product is in fault status, the buzzer will work 1-3s every minute to remind the user to maintain the product.



Dimension & Installation [mm]

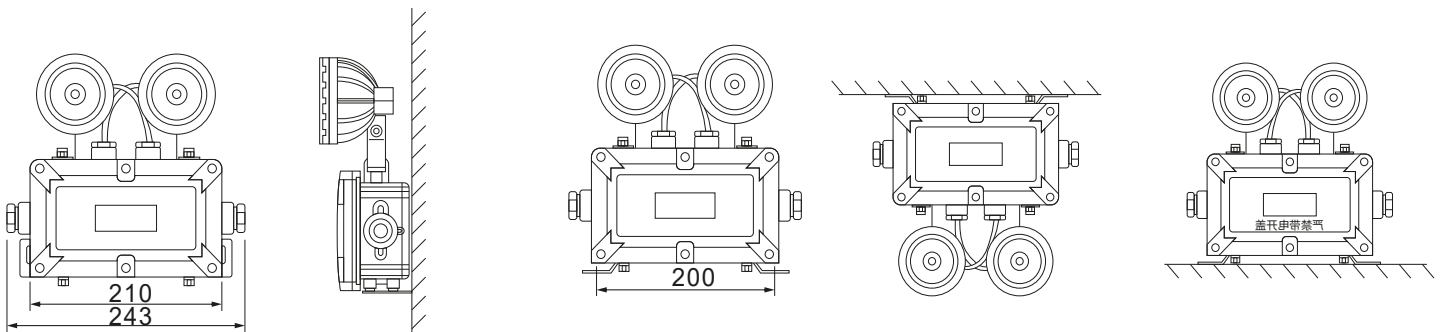

Wall Mount

Ceiling

Base